

# ARG100 Rain Gauge

## User Manual



PUBLISHED BY

**Environmental Measurements Limited (EML)**

7 Jupiter Court

Orion Business Park

North Shields NE29 7SE

United Kingdom

Visit our internet pages at <http://www.emltd.net>



©EML 2017

No part of this manual may be reproduced without any form or by any means, electronic or mechanical (including photocopying), nor may its contents be communicated to a third party without prior written permission of the copyright holder.

The contents are subject to change without prior notice.

Please observe that this manual does not create any legally binding obligation for EML towards the customer or end user. All legally binding commitments and agreements are included exclusively in the applicable supply contract or Conditions of Sale.

## Table of Contents

|   |           |
|---|-----------|
| List of Figures .....   | 4         |
| List of Tables .....  | 4         |
| <b>1. General Information</b> .....                               | <b>5</b>  |
| About this Manual .....   | 5         |
| Version Information .....   | 5         |
| Related Manuals .....   | 5         |
| <b>2. Introduction</b> .....                                      | <b>6</b>  |
| <b>3. Site and Installation Requirements</b> .....                | <b>6</b>  |
| Choosing a site .....   | 6         |
| Levelling the rain gauge .....                                    | 6         |
| Baseplate method of levelling .....                               | 7         |
| Paving slab method of levelling .....                             | 8         |
| Levelling the rain gauge using a spirit level .....               | 8         |
| Alternative mounting options.....                                 | 8         |
| <b>4. Wiring Guidelines</b> .....                                 | <b>9</b>  |
| ARG100/STD rain gauge.....  | 9         |
| ARG100/EC rain gauge.....   | 9         |
| ARG100/STD rain gauge with Limpet XL datalogger.....              | 9         |
| <b>5. Operation</b> .....   | <b>10</b> |
| Operation of the gauge.....                                       | 10        |
| <b>6. Maintenance and Calibration</b> .....                       | <b>11</b> |
| Basic Maintenance .....   | 11        |
| Calibration.....  | 11        |
| <b>7. Specifications</b> .....                                    | <b>12</b> |
| Gauge Specifications.....   | 12        |
| Cable Specifications (if fitted) .....                            | 12        |
| <b>Appendix A – ARG100 products, accessories and spares</b> ..... | <b>13</b> |

## List of Figures

|   |    |
|---|----|
| Figure 1 – Baseplate method of levelling the rain gauge .....                                       | 7  |
| Figure 2 - Paving slab method of levelling the rain gauge .....                                     | 8  |
| Figure 3 - Reed switch and resistor.....  | 9  |
| Figure 4 - Filter and filter cap (left) / Nozzle delivering water into tipping bucket (right) ..... | 10 |

## List of Tables

|  |    |
|--|----|
| Table 1 - Document Revisions.....                | 5  |
| Table 2 - Related Manuals .....                  | 5  |
| Table 3 - Gauge Specifications .....             | 12 |
| Table 4 - Cable Specifications (if fitted) ..... | 12 |
| Table 5 – ARG100 products.....                   | 13 |
| Table 6 - Accessories for the ARG100 .....       | 13 |
| Table 7 - Spare parts for the ARG100 .....       | 13 |

# 1. General Information

## About this Manual

This manual is intended as a general guide for installing, wiring and using the ARG100 rain gauge. The information contained in this manual may not cover all aspects of ARG100 applications. Please refer to associated equipment manuals or consult papers and technical notes on the EML website ([www.emltd.net](http://www.emltd.net)).

## Version Information

*Table 1 - Document Revisions*

| <b>EML Document Number:</b> | <b>Description:</b>  |
|-----------------------------|--|
| UM-P-780-400                | Version 1.00 - First Release, dated 16 <sup>th</sup> June 2002 |
| UM-P-780-400                | Version 1.12 - Second Release, dated 25 <sup>th</sup> May 2017 |
| UM-P-780-400                | Version 2.00 – Third Release, dated 1 <sup>st</sup> March 2018 |
|                             |  |

## Related Manuals

*Table 2 - Related Manuals*

| <b>EML Document Number:</b> | <b>Description:</b> |
|-----------------------------|---------------------|
|                             |                     |
|                             |                     |
|                             |                     |
|                             |                     |

## 2. Introduction

The ARG100 is EML's recommended solution for professional water industry applications such as water authorities and companies. It is EML's longest serving product which has been used on thousands of professional standard weather stations.

Traditional cylinder-shaped rain gauges are inaccurate due to the effect of wind blowing over the orifice. The physical presence of the gauge causes air to accelerate, carrying rainfall away from the collecting vessel. The effect of this can be up to a 20% reduction in rainfall catch. The unique aerodynamic shape of the EML range of scientific standard rain gauges reduces this effect, ensuring a high level of confidence in the accuracy of the measurements.

## 3. Site and Installation Requirements

### Choosing a site

A rain gauge site is often a compromise between exposure requirements and operational constraints. The ideal site is level ground with a uniform scattering of objects in the surrounding area thus reducing overall wind speeds. However, these objects should not be too large to cause eddying or high gusts to occur near to the gauge, or so close to prevent rain from entering the gauge. The gauge should ideally be no closer than at least twice the height of the obstruction. Although the ARG100 rain gauge is designed to operate in higher wind speeds, care must still be taken to avoid over-exposing the gauge where possible. Large expanses of open flat land should be avoided where possible. If the application is very specific, such as monitoring a building site, then the siting of the rain gauge is largely prescribed by use. Those users who wish to enquire more fully into rain gauge exposure are referred to the EML website for more technical information and papers ([www.emltd.net](http://www.emltd.net)).

**NOTES:** No two rain gauge designs are ever likely to produce identical results, and even two identical rain gauges can give slightly different catches even when sited close to each other.

If the gauge is to be operated in the area of livestock, then a fence will almost always be required to prevent damage from and to the animals.

**WARNING! Remove packing piece!** The tipping-bucket mechanism is immobilised before shipping to prevent damage in transit. To release the mechanism for use, remove the funnel assembly from its base by loosening the three screws and then lifting the funnel. Remove the piece of foam from under the bucket mechanism. This foam may be saved and used whenever the rain gauge is transported.

### Levelling the rain gauge

The ARG100 can be mounted directly on to any flat surface, and securely fastened as desired, for example by using three rawbolts to a paving slab. However, it is recommended that the rain gauge is mounted to the RGB1 baseplate, which can then be mounted to any flat surface. This makes levelling of the rain gauge easier. The two methods are now described.

## Baseplate method of levelling

1. Assemble the rain gauge base and the baseplate as in Figure 1
2. Fix the baseplate on soft ground using the 4 pegs supplied. If force is needed then remove the rain gauge first.

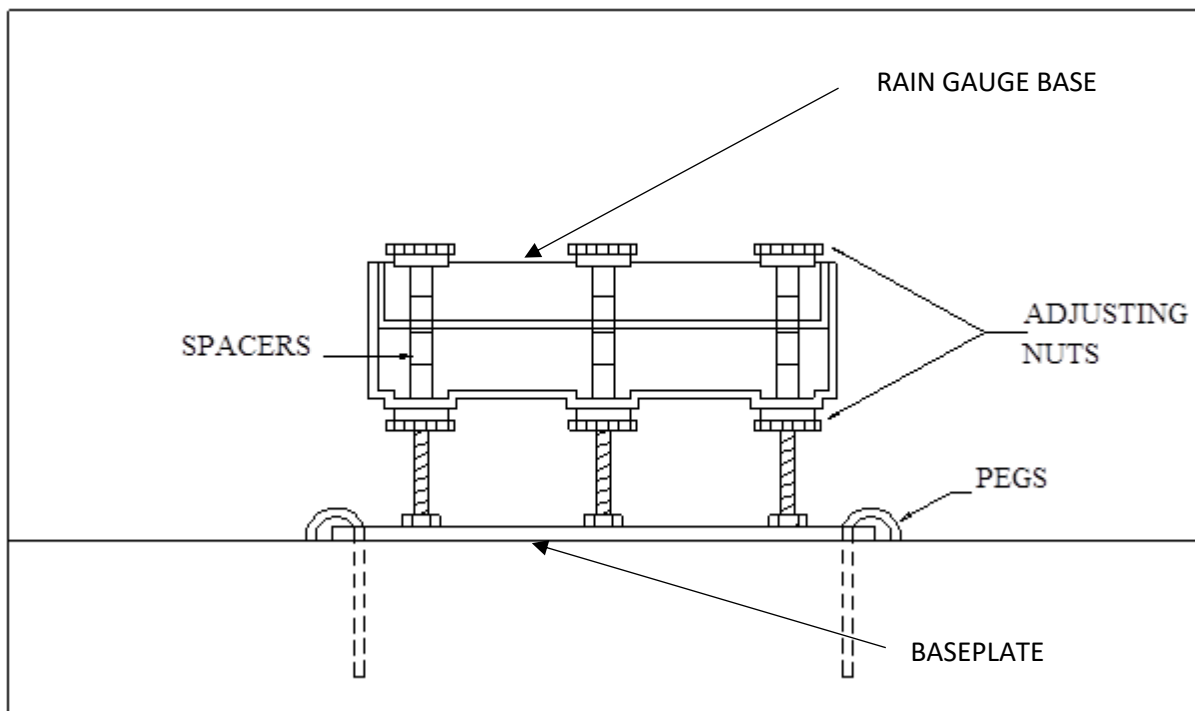

*Figure 1 – Baseplate method of levelling the rain gauge*

**NOTE:** The baseplate may be mounted to hard surfaces like concrete by replacing the pegs with screws and rawlplugs. For temporary mounting on hard surfaces use some bricks or heavy weights on the four corners of the baseplate (the height of the weights should be kept as low as possible to cause the minimum interference with the aerodynamics of the rain gauge).

## Paving slab method of levelling

1. Drill slab to suit studs
2. Drill out three holes in the rain gauge base to suit studs and deburr
3. Assemble all as shown in Figure 2
4. Position on ground and level carefully

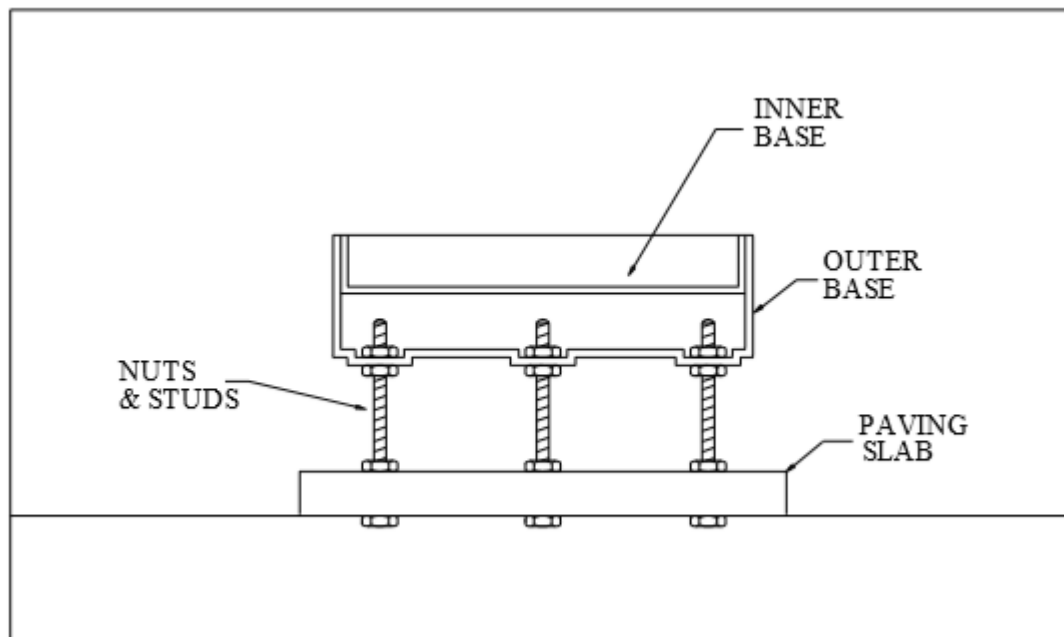

Figure 2 - Paving slab method of levelling the rain gauge

## Levelling the rain gauge using a spirit level

The gauge must be levelled for correct operation, and it is important to ensure that the rim of the rain gauge is levelled precisely, using a spirit level; failure to do this will result in a systematic error. Levelling is one of the simplest means of improving accuracy of rainfall measurements. Although a small circular spirit level is provided in the base of the rain gauge, this is provided only as a quick check system, always level the rim of the funnel precisely and check regularly.

## Alternative mounting options

It is not always possible to mount a rain gauge on the ground surface. Examples of applications which make use of rain gauges mounted above the ground include; urban monitoring, areas prone to ground-flooding and areas prone to snowfall. It should be noted that regardless of which option is used to mount the gauge, it must be firmly fixed and not susceptible to vibration. Vibration may lead to 'false-tipping' of the bucket mechanism and thus contribute to erroneous or inaccurate measurements. There are options which can be used to mount the ARG100 above the ground. The ARG100 can be purchased with a rain gauge pedestal and guy kit or a rain gauge pedestal only.



## 4. Wiring Guidelines

This section gives information on the wiring of ARG100 rain gauge.

For most applications, the rain gauge may be connected directly to a pulse counting input (contact closure) on a data logger, but some care is needed if long cables are used. In a long cable significant capacitance can exist between the conductors, which discharges across the reed switch as it closes. As well as shortening the life of the switch, a voltage transient may be induced in any other wires which run close to the rain gauge cable each time the rain gauges tips. To help this situation, 100Ω resistors are pre-fitted to each of the reed switches (Figure 3), these will help protect the switches from arcing and help prevent transients.

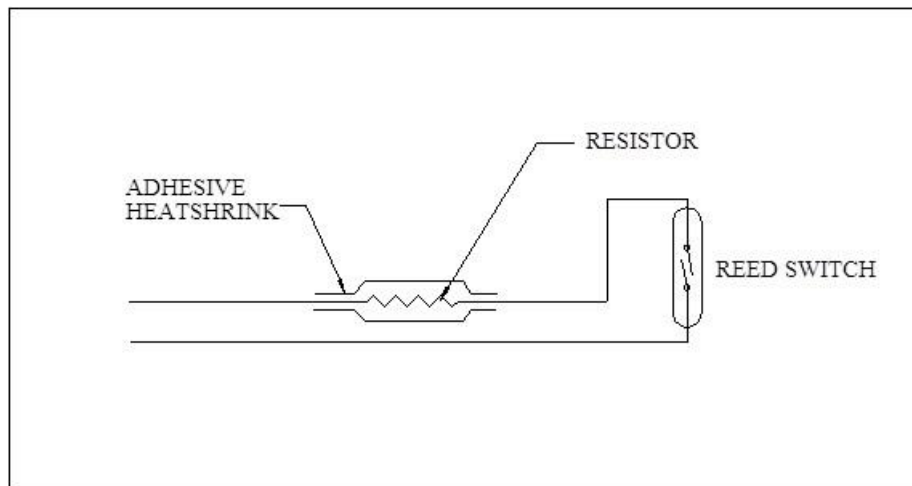

*Figure 3 - Reed switch and resistor*

**NOTE:** The type of measurement is contact closure (switch), therefore it does not matter which way round the wires from the logger or counter are connected.

### ARG100/STD rain gauge

This is the standard version of the rain gauge which is supplied with two short lengths of wire approximately 220mm. The series resistor shown in Figure 3 is inserted in one wire and covered by adhesive type heatshrink sleeving.

### ARG100/EC rain gauge

The ARG100/EC is supplied fitted with a 6-metre extension cable. One wire is attached to the resistor and covered with adhesive type heatshrink. The other wire is attached, covered with heatshrink and the entire joint covered again with heatshrink. The cable passes through a grommet in the outer base.

The cable length may be shortened or lengthened as required. If the cable is lengthened, please ensure a good quality environmental connector, or a heatshrink joint similar to the one described previously, is used. Extension cables used must be of a similar specification.

### ARG100/STD rain gauge with Limpet XL datalogger

If the ARG100 rain gauge is ordered with an EML Limpet XL datalogger and accessories, a specific connector will automatically be fitted that is compatible with the logger.

## 5. Operation

### Operation of the gauge

Rainfall is measured by the well-proven tipping bucket method. Precipitation is collected by the funnel and flows through a plastic gauze filter, trapping and removing any leaves, dirt, etc. Figure 4. Water then drips from the nozzle into one of the two halves of the tipping bucket.



*Figure 4 - Filter and filter cap (left) / Nozzle delivering water into tipping bucket (right)*

The internal tipping bucket assembly rotates around precision rolling pivot bearings. The balance arm tips when the first bucket is full, emptying this rain water and positioning the second bucket under the funnel. The tipping process repeats indefinitely as long as the rain continues to fall, with each tip corresponding to a calibrated fixed quantity of rainfall. At each tip of the bucket the moving arm forces the magnet past the reed switch causing contact to be made for a few milliseconds. As each bucket side is used in turn, the outgoing water is drained into the base of the gauge, before flowing out through plastic gauze filters.

**NOTE:** The exact calibration of each tip is pre-set by adjustable stops located beneath each tipping bucket compartment. Do not alter these stops unless as part of a calibration exercise. A levelling bubble is provided as an aid to levelling of the rain gauge. Connections to the reed switches are made via the connector terminals.

## 6. Maintenance and Calibration

### Basic Maintenance

To ensure reliable and accurate measurements it is recommended that the following checks are carried out at each visit to the rain gauge (if the gauge is still connected to a data logger and the logger is operating, care must be taken to avoid tipping the bucket when carrying out these checks).

1. Inspect the funnel and filter for any damage or blockage. At certain times of the year, particularly autumn, leaves may accumulate in the funnel, dirt and dust can also block the filter preventing or reducing the flow rate to the buckets beneath. The leaves can easily be removed from the funnel and the filter cleaned by removing the end cap from the filter tube, remove the stainless-steel filter gauze carefully, clean and re-fit the filter and cap.
2. Check that the gauge is still level. Small movements may occur over time.
3. Remove and clean any dirt from the tipping bucket, being careful not to tip the bucket should the rain gauge still be logging.
4. During any occasion when the rain gauge is disconnected from the logger, it is good practice to check the balance arm of the tipping bucket for stiffness. The easiest way to do this in the field is to try and balance the bucket in its centre position, it should be very difficult if not impossible to achieve this, if the bucket balances easily then examine the bucket closely for any dirt or wear on the pivot pin and bucket tubes.

**NOTE:** A spares kit is available with filter, cap, and screws. Contact EML sales ([sales@emltd.net](mailto:sales@emltd.net)) for more information.

### Calibration

The sensitivity of the rain gauge is accurately calibrated during the manufacturing to a nominal 0.2mm/tip using a purpose-built calibration rig supplying an adjustable constant head of water allowing accurate calibration of the rain gauge. Each rain gauge is supplied with its own calibration figure to three decimal places. All gauges are calibrated to a tolerance of 2% of the 0.2mm tip value.

A re-calibration and overhaul service is also offered to customers; EML recommends re-calibration every 12 to 24 months depending on applications.

For information on how we calibrate the rain gauges see British Standards document BS 7843-1:2012 and the CIMO Guide to Meteorological Instruments and Methods of Observation (Chapter 6). These documents describe the processes of bucket balancing, static calibration at a fixed intensity, and dynamic calibration using variable intensities

## 7. Specifications

### Gauge Specifications

Table 3 - Gauge Specifications

| Technical Specifications |  |
|--------------------------|--|
| Resolution               | 0.2mm or 0.25mm / 0.01 inch                              |
| WMO Compliant            | Yes  |
| Output                   | Contact Closure (Reed Switch)                            |
| Typical Accuracy         | 99% up to 120mm/hr                                       |
| Rainfall Intensity       | 0-500 mm/hr (with mathematical correction - contact EML) |
| Operating Temperature    | 1°C - 70°C   |
| Funnel Diameter          | 25.4cm / 10 Inch   |
| Funnel Area              | 506.7cm <sup>2</sup> / 78.54 sq. Inch                    |
| Height                   | 31.5cm or 40.0cm max with baseplate                      |
| Weight                   | 1Kg or 2Kg (with baseplate)                              |
| Colour                   | White  |

### Cable Specifications (if fitted)

The standard cable used in all extended versions (on request) of the rain gauge is a single twisted pair of 7/0.25mm (22awg) tinned copper conductors, insulated with polyethylene, wrapped in an aluminised tape with a 7/0.25mm tinned drain wire and a PVC outer sheath.

Table 4 - Cable Specifications (if fitted)

| Technical Specifications |   |
|--------------------------|---|
| Temperature Range        | -30°C to +70°C  |
| Overall diameter         | 4.6 mm  |
| Char. impedance          | 85 Ω  |
| Capacitance/metre        | 154 pF  |
| Equivalents              | <b>Alpha</b> 2401<br><b>Belden</b> 8761<br><b>UL style</b> 2092 |

## Appendix A – ARG100 products, accessories and spares

Table 5 – ARG100 products

| Product code | Description   |
|--------------|---|
| P-780-001    | ARG100/STD – Standard                                 |
| P-780-010    | ARG100/EC - Standard with 6m cable                    |
| P-780-002    | ARG100/L - Standard with plug for internal EML logger |
| n/a          | ARG100 with other cable length available on request   |

Table 6 - Accessories for the ARG100

| Product code | Description                       |
|--------------|-----------------------------------|
| P-780-188    | Rain gauge Pedestal + Guy Kit     |
| P-780-189    | ARG/SBS Pedestal                  |
| P-780-195    | RGB1 - Baseplate for ARG100 gauge |
| P-780-050    | ARG100 spares kit                 |

Table 7 - Spare parts for the ARG100

| Product code | Description                      |
|--------------|----------------------------------|
| P-780-040    | ARG100 Calibrated Inner Assembly |
| P-780-050    | ARG100/SKIT Raingauge Spares Kit |
| P-780-100    | ARG100 Funnel Assembly           |
| P-780-105    | ARG100 Inner Assembly            |
| P-780-110    | ARG100 Base Assembly             |
| P-780-115    | ARG100 Bucket Assembly           |
| P-780-117    | ARG100 Calibration               |
| S-895-010    | ARG Reed Switch                  |